

1 White side up

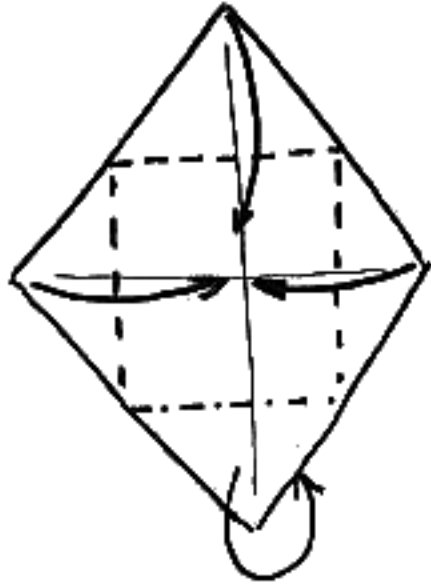

2

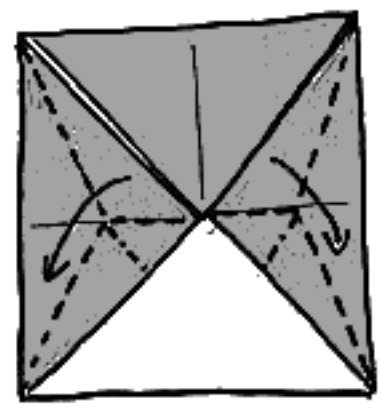

Rabbit ear folds

3

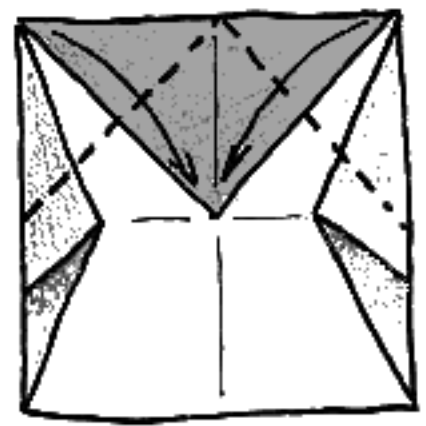

Turn over

4

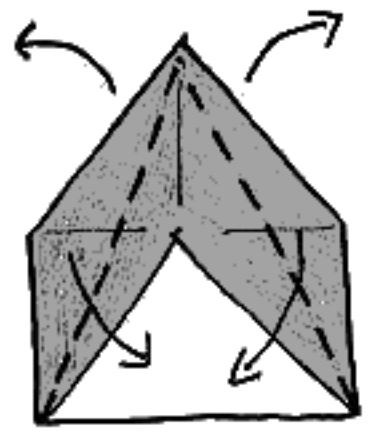

Bring flaps from behind

5

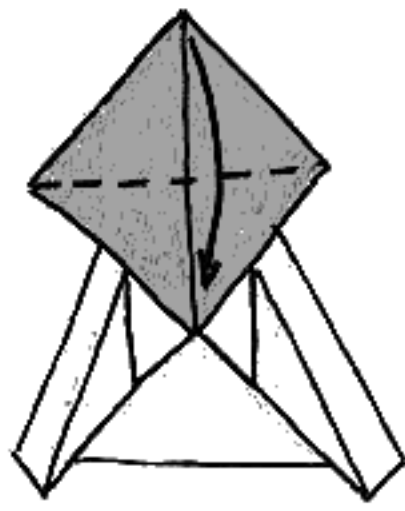

6

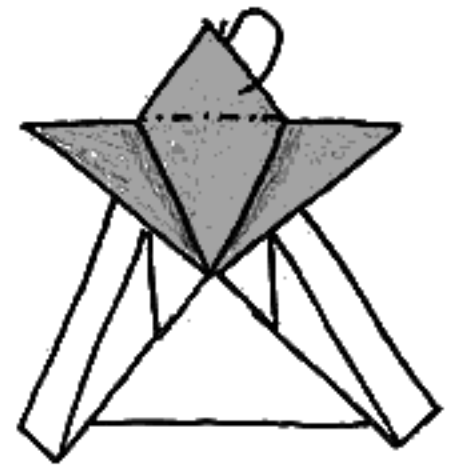

Tuck into pocket behind

7

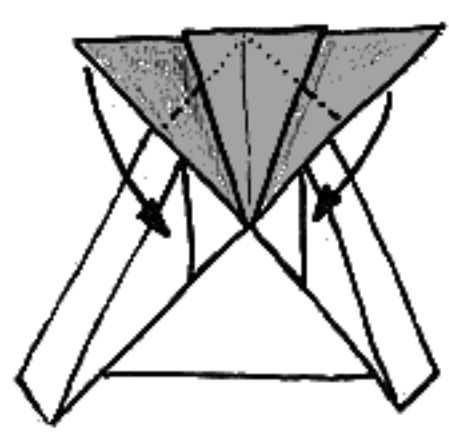

Reverse folds

8

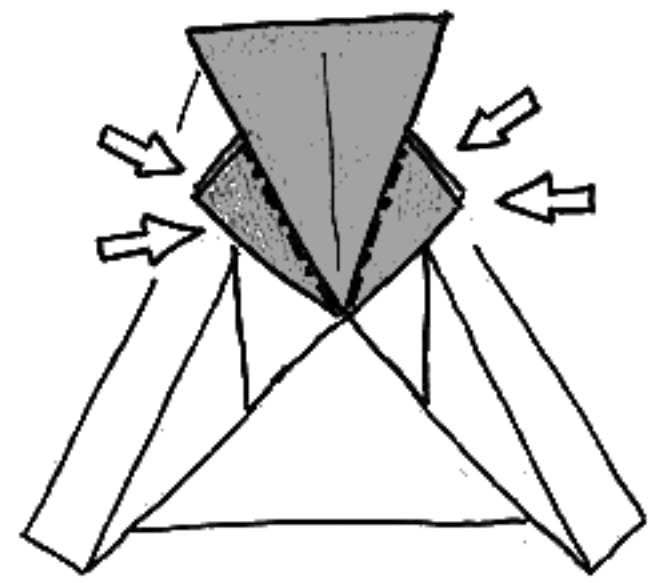

Four more Reverse folds

9

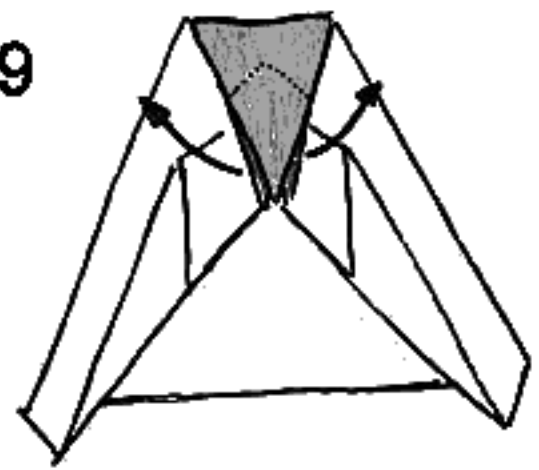

Form ears

10

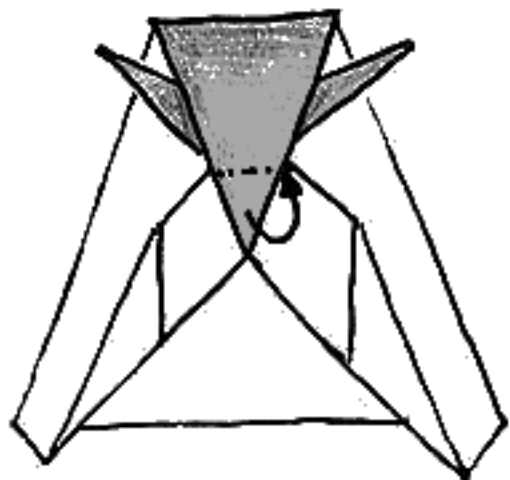

Fold flap behind

11

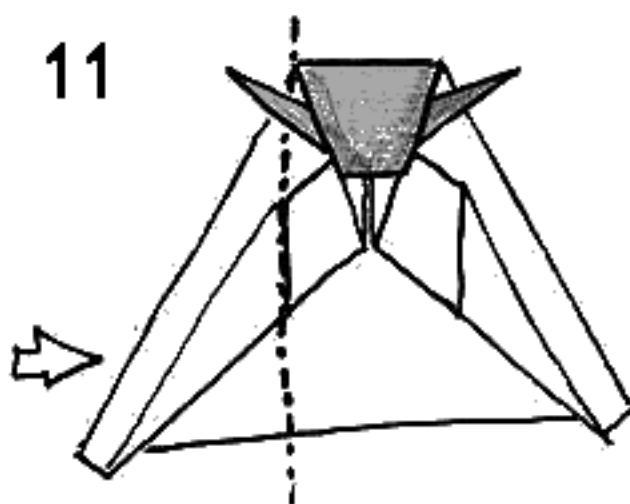

Reverse fold
inside model

12

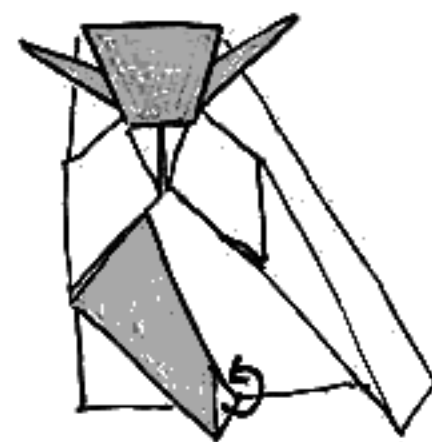

Wrap white
layer to behind

13

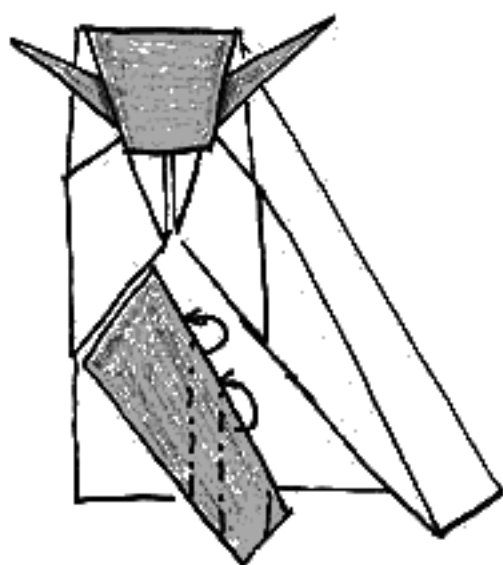

14

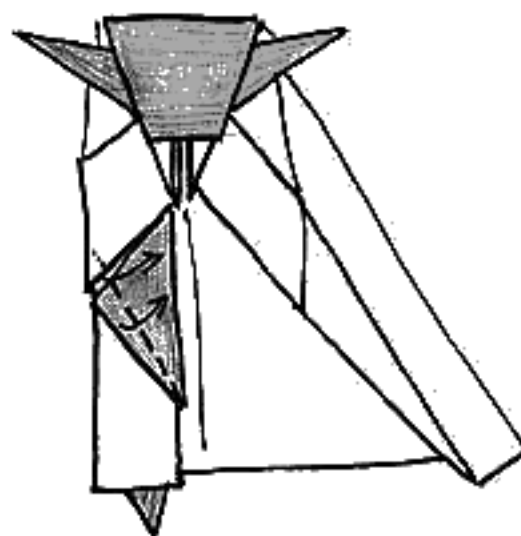

Make this flap white with
a valley fold. A reverse
fold under the arm may
be needed

15

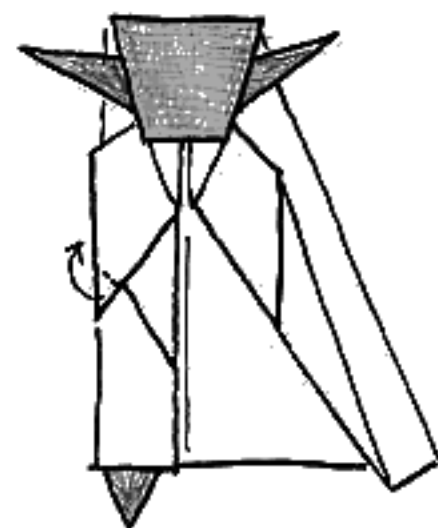

Outside reverse
fold to form hand

16

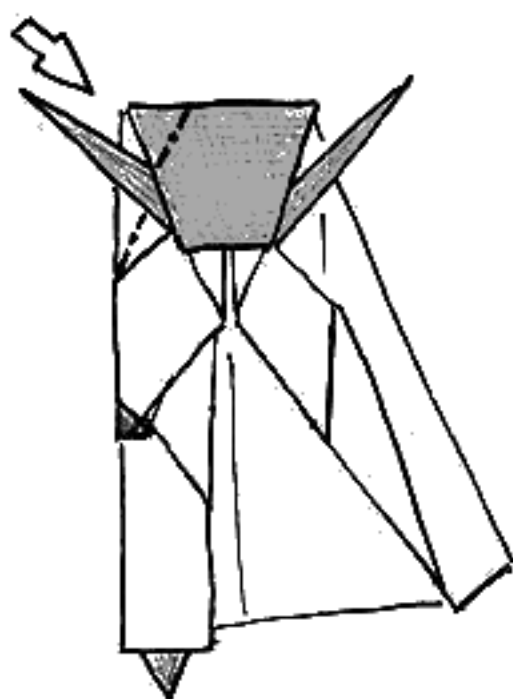

Closed sink

17

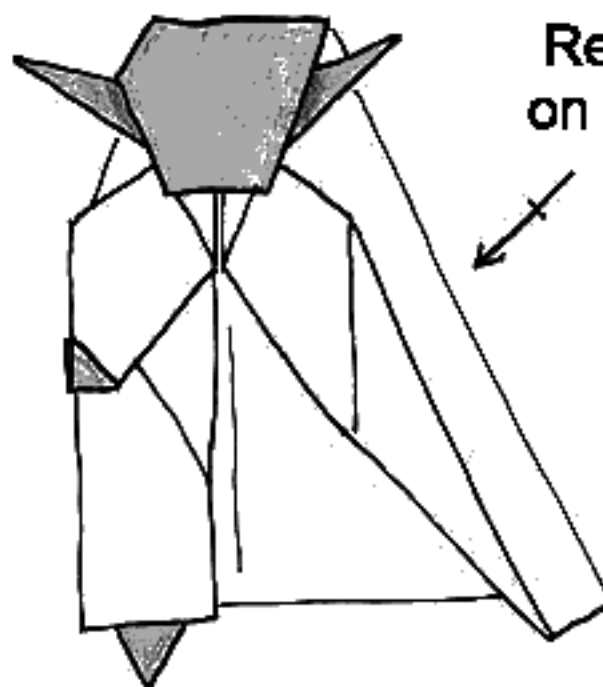

Repeat steps 11 - 16
on the right side of the
model

18

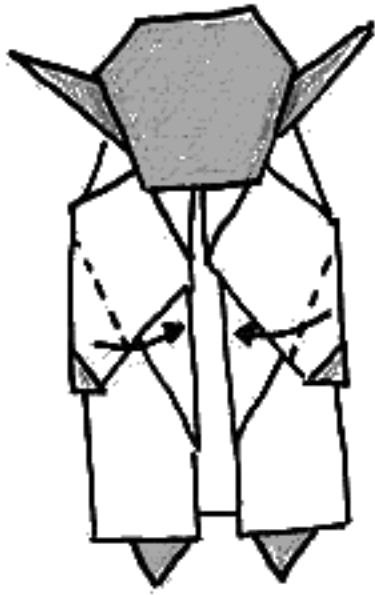

Fold arms to centre

19

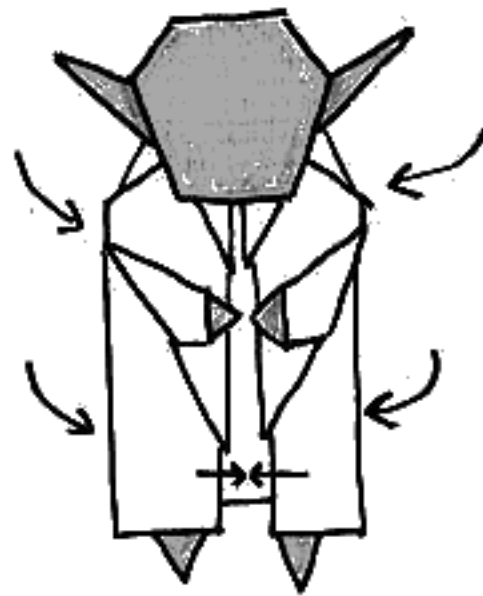

Round body by bringing front of robes together

20

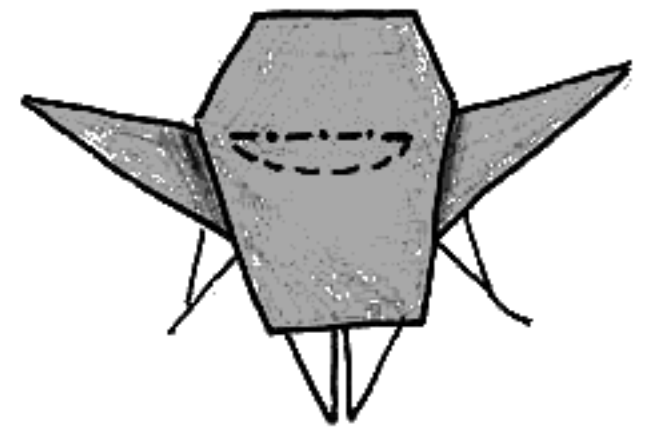

Pinch these folds with thumbnail

21

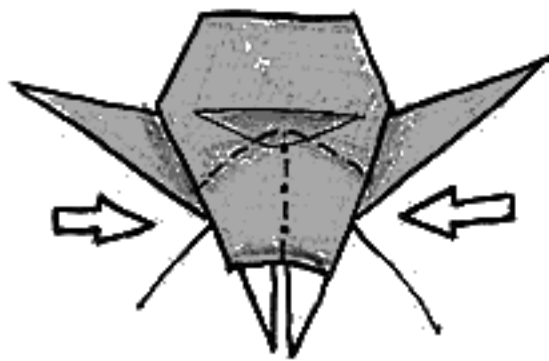

Pinch between fingers to form face...

22

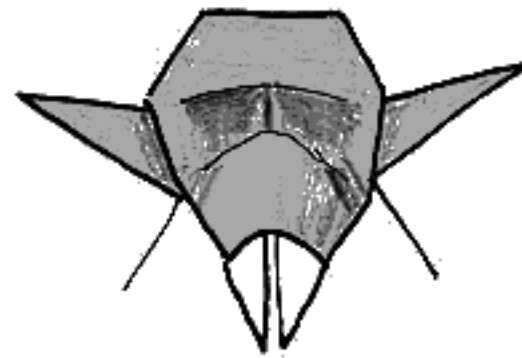

...like so

Finished Yoda

