

3

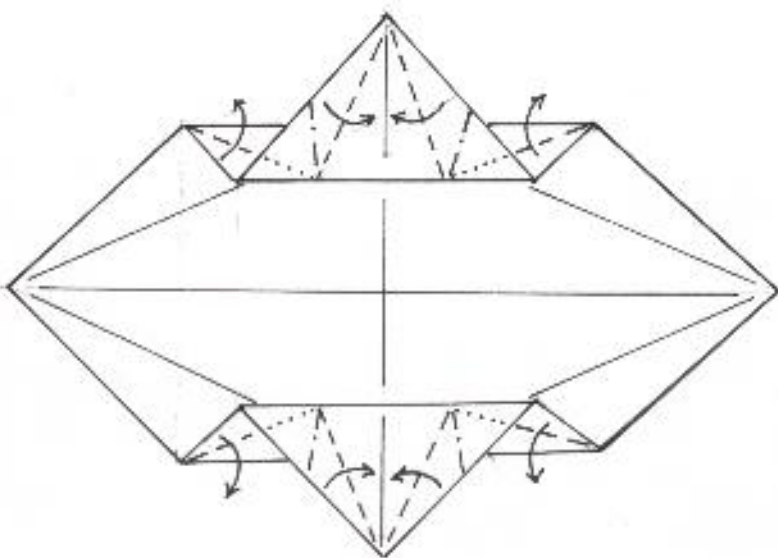

4

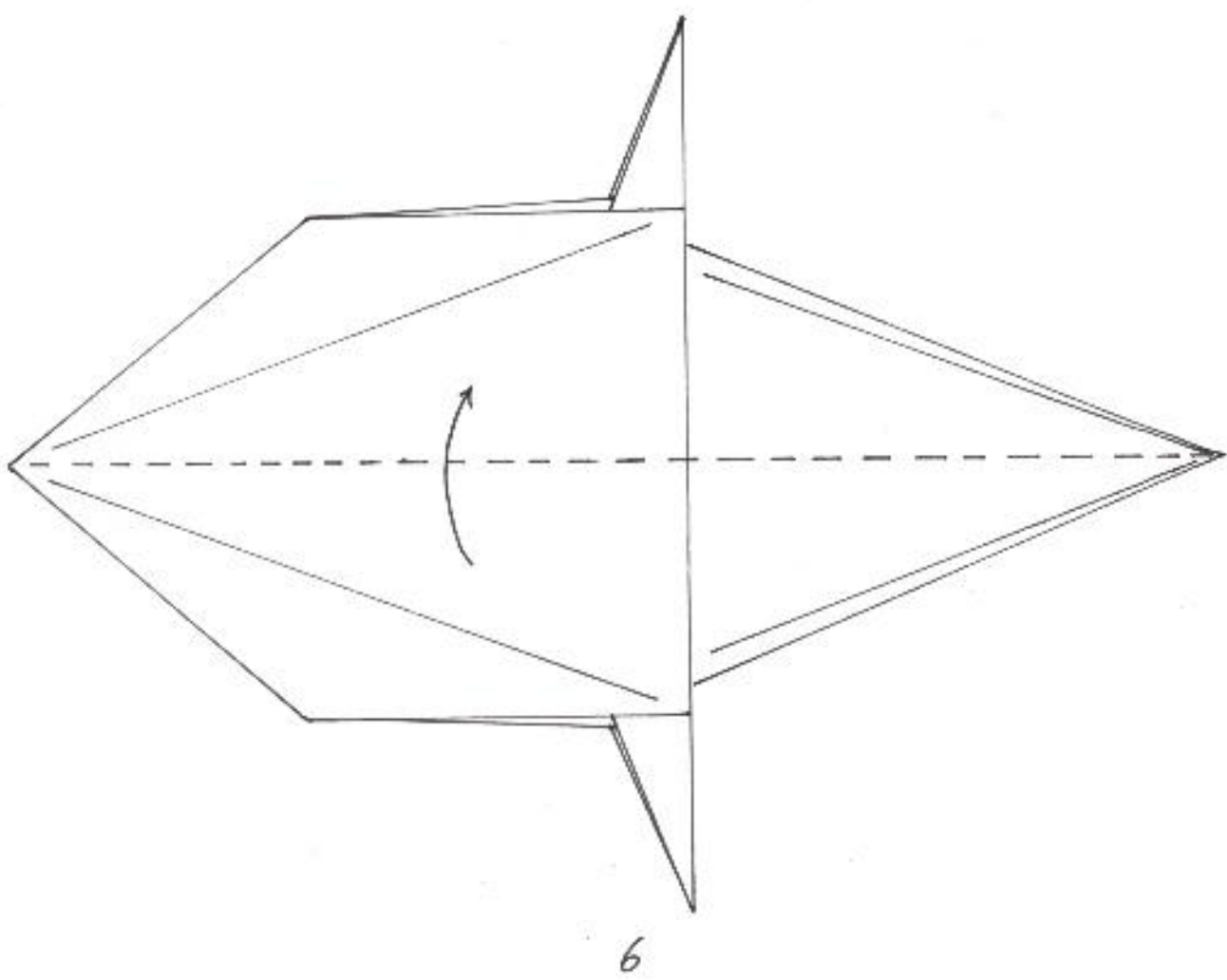

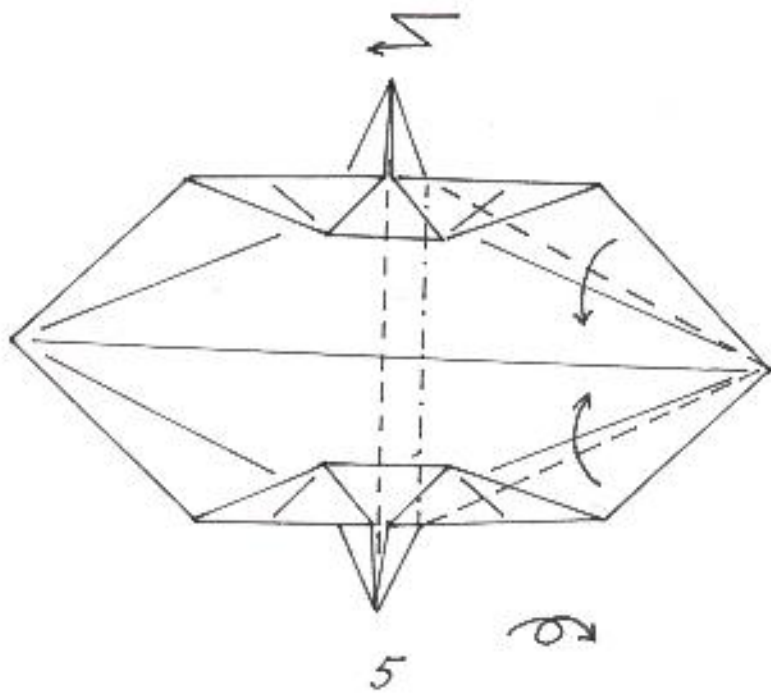
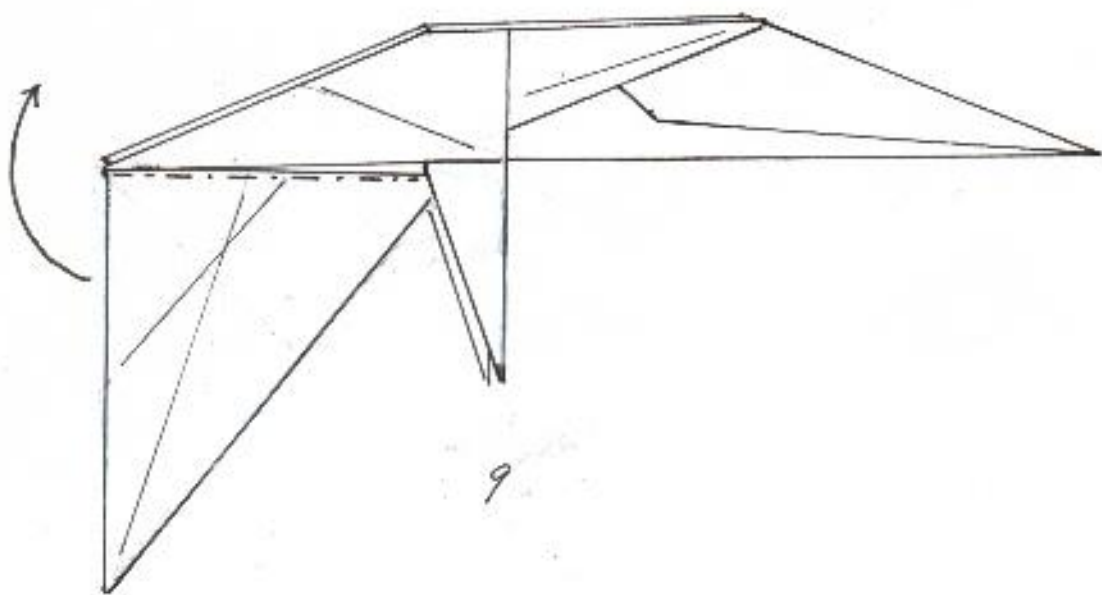
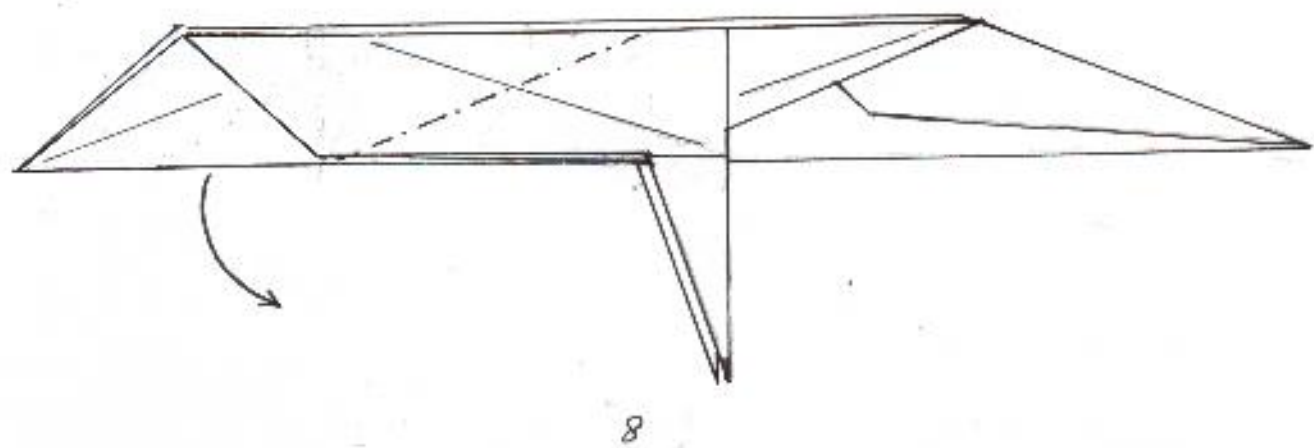
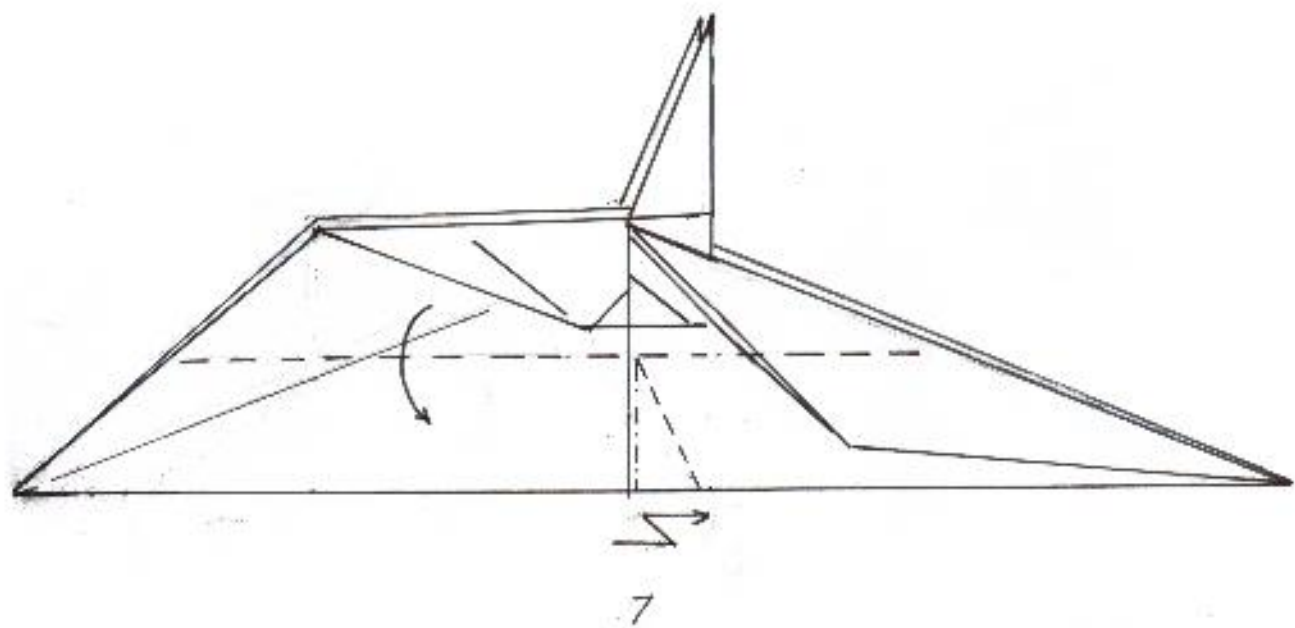

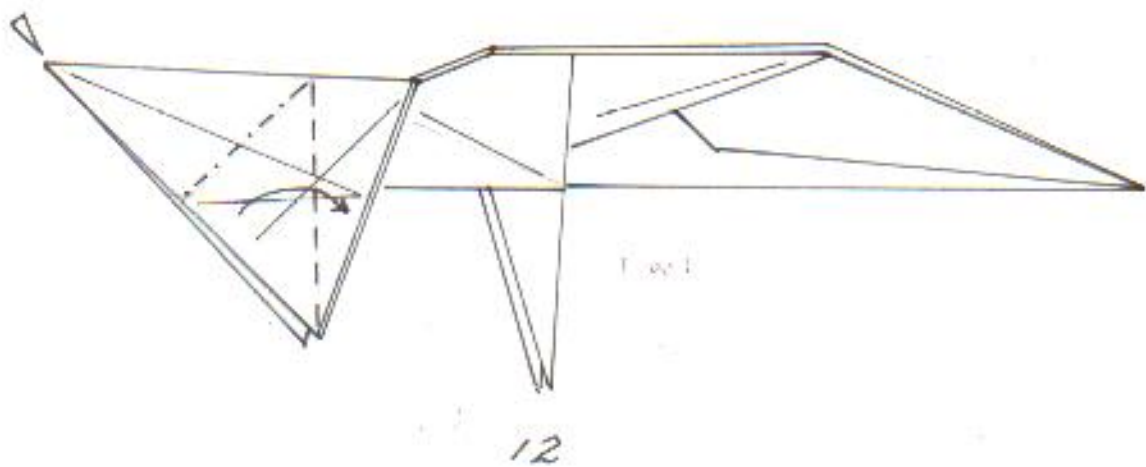
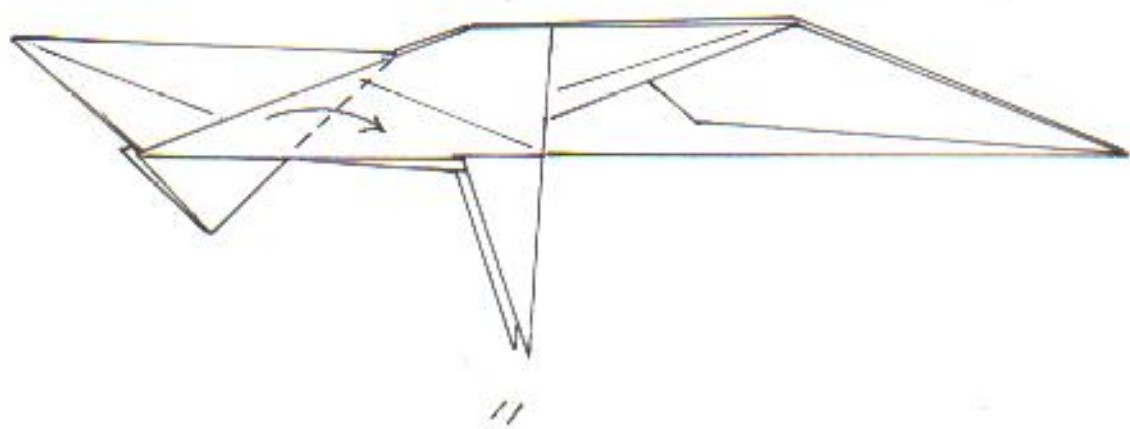
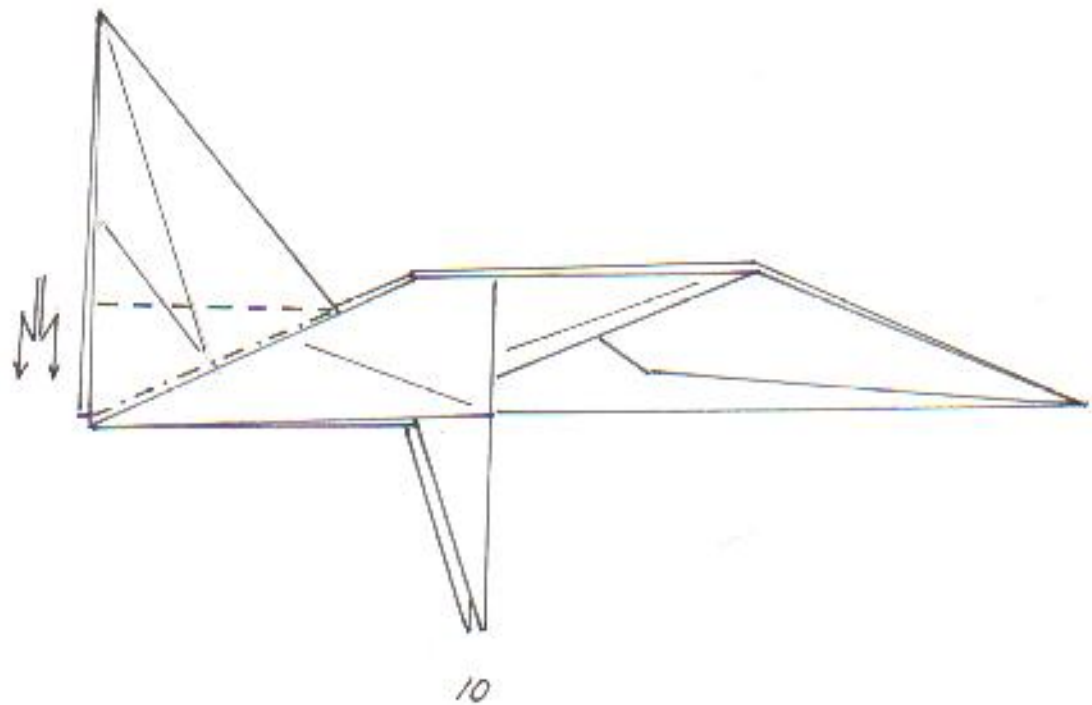

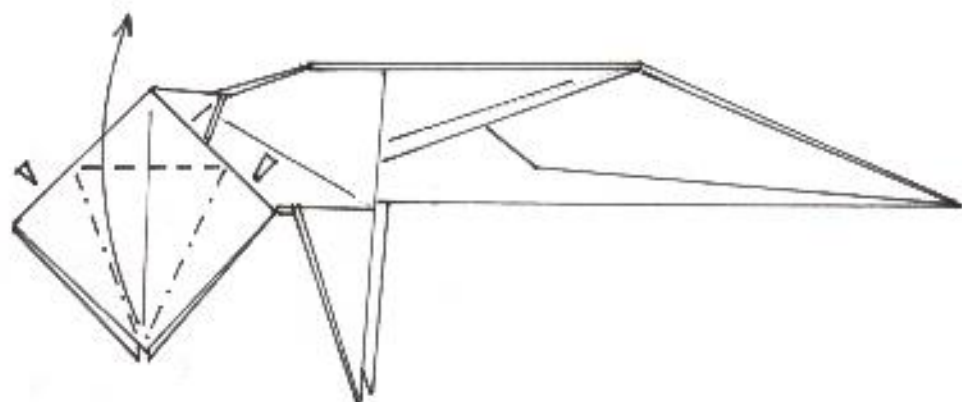

13

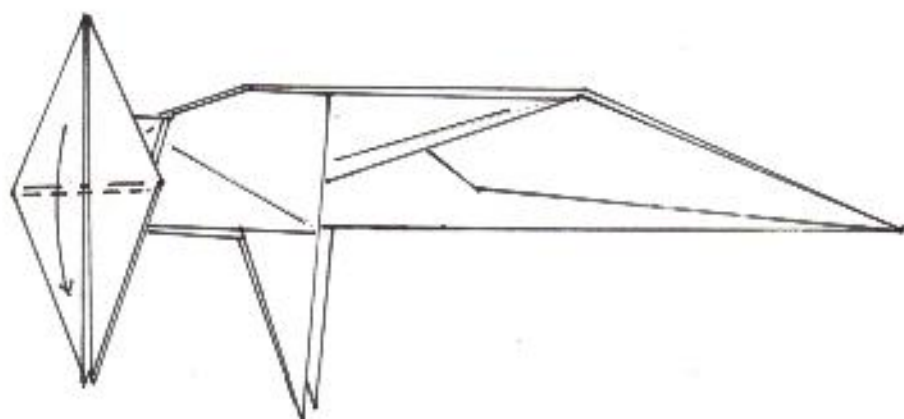

14

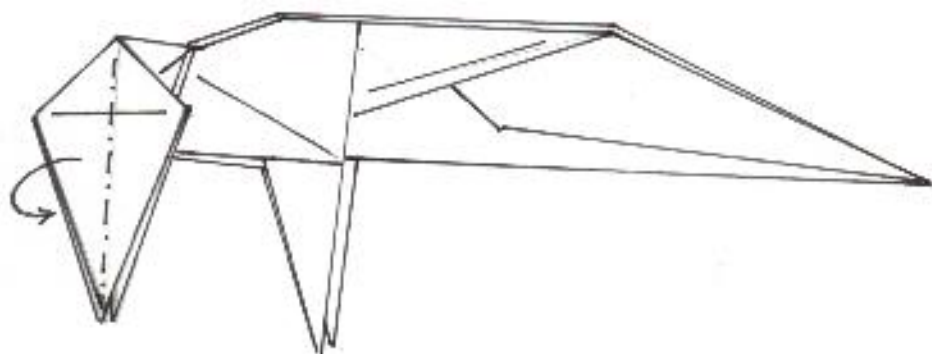

15

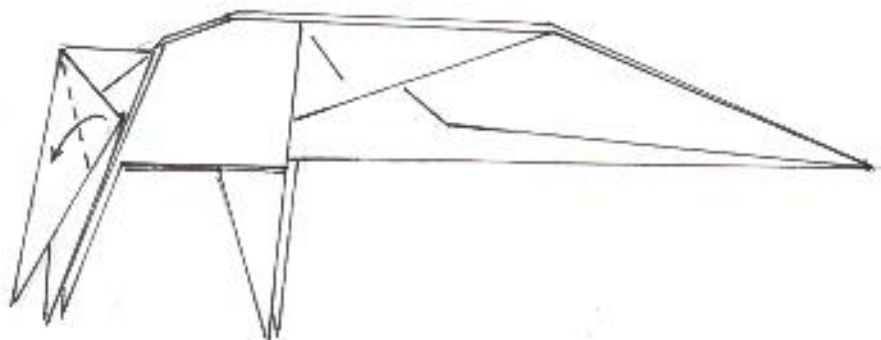

16

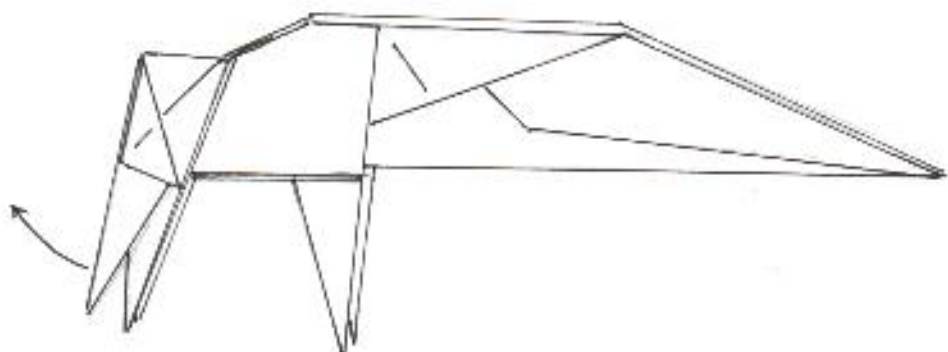

17

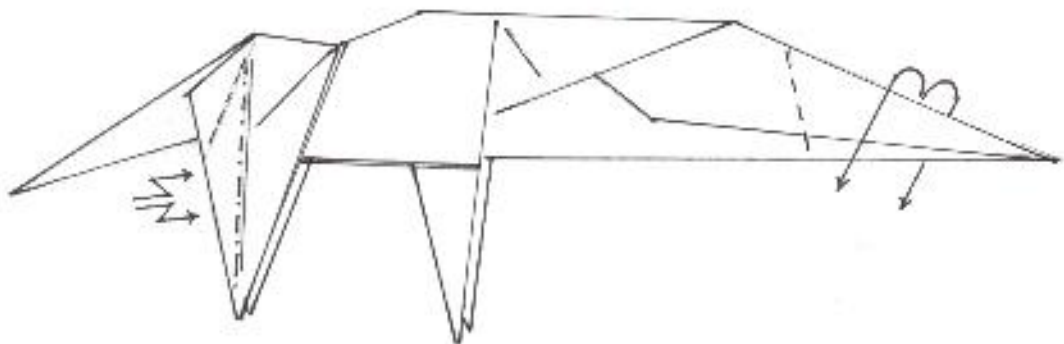

18

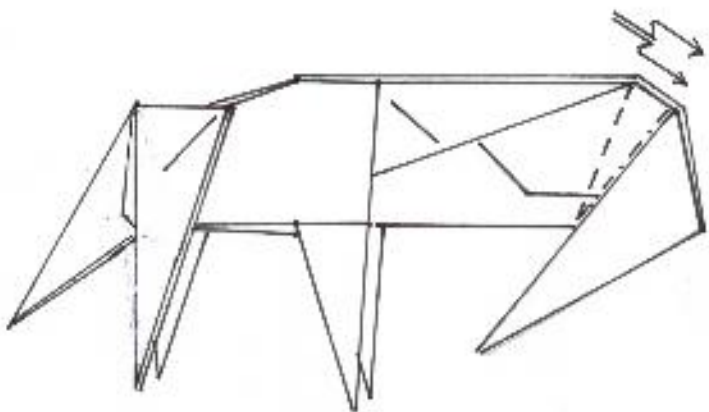

19

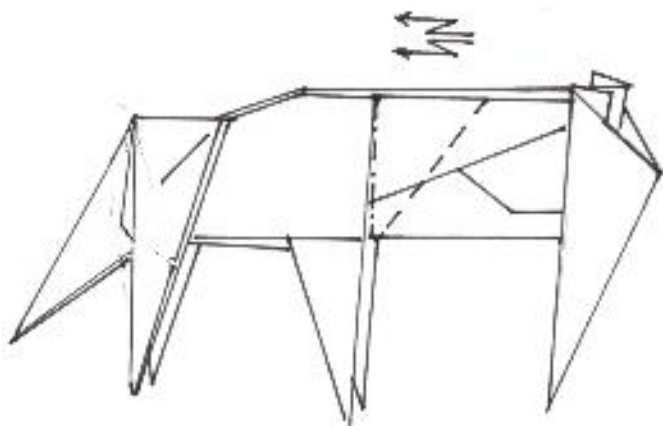

20

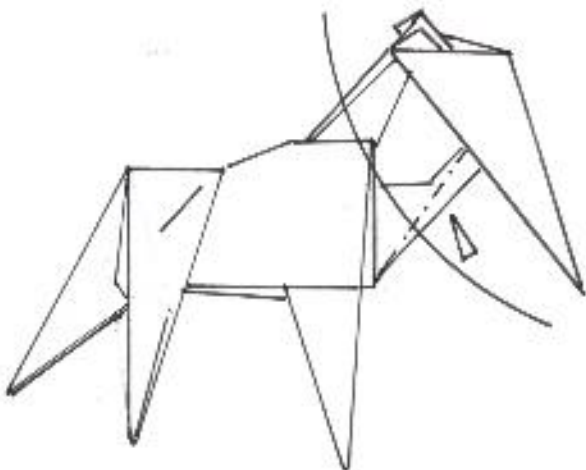

21

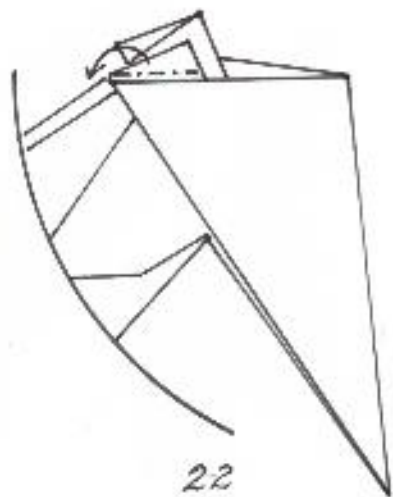

22

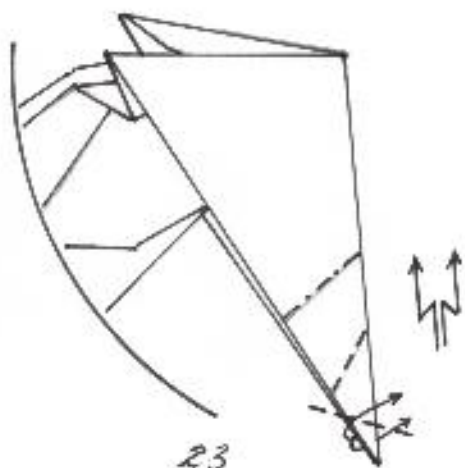

23

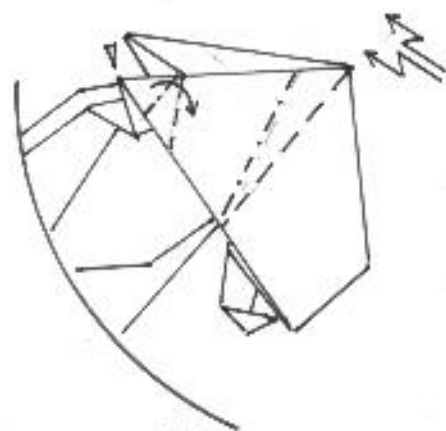

24

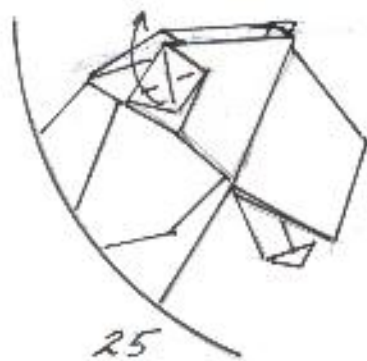

25

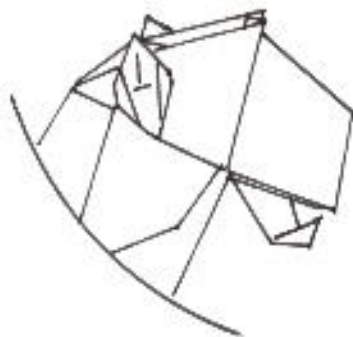

26

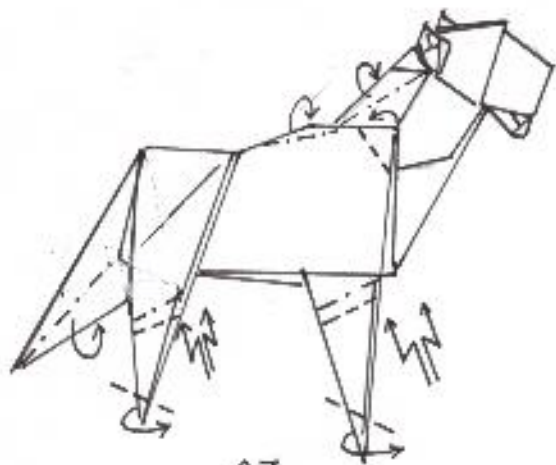

27

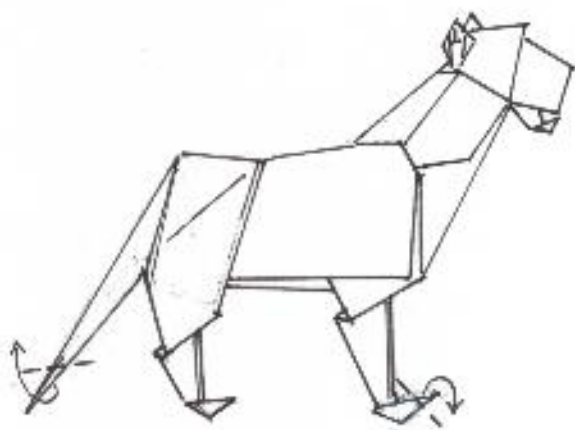

28

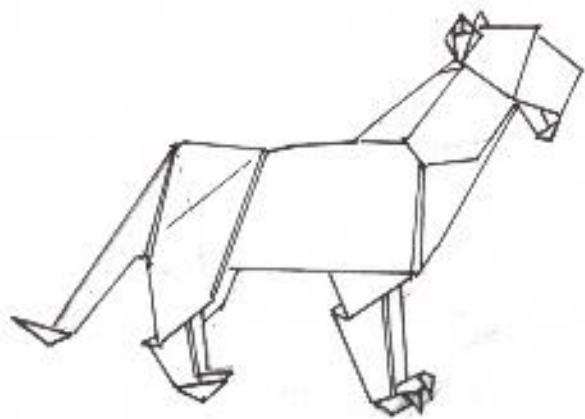

29

## TIGER

1. Use a square paper. Crease the diagonals. Unfold.
2. Valley-fold the existing creases. Unfold.
3. With the existing creases, pleat-fold one quarter of the bottom flap. Repeat the same process on the top flap of the paper.
4. With the existing creases, narrow the top and bottom triangular flaps to form the front legs.
5. Valley-fold the right sides of the flap. Pleat-fold the centre of the model. Turn it over.
6. Valley-fold the model in half.
7. Pleat -fold the mid bottom of the model. Unfold. Valley-fold the model horizontally in half.
8. Inside reverse-fold the left part of the model, pulling it down as far as it can stretch.
9. Inside reverse-fold the left triangular flap upwards.
10. Crimp the triangular flap.
11. Valley-fold the top left flap. Repeat behind.
12. Squash-fold the triangular flap.
13. With the existing creases, petal-fold the top flap.
14. Swing the top triangular flap down with a valley fold to form the hind legs.
15. Narrow the leg part with a mountain fold.
16. Valley-fold the tail part.
17. Stretch the tail part as far as it can go.
18. Crimp the leg part to narrow it. Outside reverse-fold the right flap to the head.
19. Crimp the head part.
20. Crimp the neck part.
21. Narrow the neck with a mountain fold.
22. Inside reverse-fold the small triangular flap. Repeat behind.
23. Outside reverse-fold the tip of the head part. Crimp the mouth part to form the lower jaw.
24. Crimp the middle of the head part. Squash-fold the ear. Repeat behind.
25. Petal-fold the ear. Repeat behind.
26. The finished head.
27. Outside reverse-fold the tips of the legs. Crimp all the legs. Narrow the tail and the neck with mountain folds. Shape the body.
28. Outside reverse-fold the tip of the tail. Outside reverse-fold the tips of the paws to form claws. Repeat behind.
29. The completed tiger.